

AlliedWare Plus™ OS

How To | Configure Basic Switching Functionality

Introduction

This How To Note introduces a number of commonly-used switching features of the AlliedWare Plus™ operating system (OS), the next generation operating system for Allied Telesis Inc's high performance layer 3 managed switches:

- changing port speed, duplex mode, and polarity
- VLANs
- RSTP and MSTP
- link aggregation (static and using LACP)
- port mirroring

Contents

Introduction	1
Contents	1
Related How To Notes	2
Which products and software version does it apply to?	2
Port Numbering	3
Port numbers	3
Port ranges	4
Port speed, duplex mode, and polarity	5
How to set the speed	5
How to set the duplex mode	6
How to set the polarity	6
Basic VLAN and IP configuration	7

Rapid Spanning Tree Protocol (RSTP)	12
The default configuration	12
How to change the root bridge priority	14
How to set ports as edge ports	14
Multiple Spanning Tree Protocol (MSTP)	15
Link Aggregation	21
How to configure Link Aggregation Control Protocol (LACP)	21
How to configure static aggregation	24
Port mirroring	25
Appendix: Complete configuration scripts	26
Script for VLAN example	26
Script for MSTP example	28

Related How To Notes

You also may find the following AlliedWare Plus OS How To Note useful:
How To Get Started With The AlliedWare Plus™ Operating System.

Which products and software version does it apply to?

This How To Note applies to the following Allied Telesis switches, running the AlliedWare Plus OS software version 5.2.1 or later:

- SwitchBlade x908
- x900 series

Port Numbering

Port numbers

In the AlliedWare Plus OS, switch ports are named portx.y.z (e.g. port1.0.1), where:

- the first number (x) is the stack ID number
- the second number (y) is the module number.

For ports on the base unit, the module number is 0.

For XEMs, the module numbering starts at 1 on the left-hand side of the switch when you view the switch from the front, as the following figure shows for an x900 series switch:

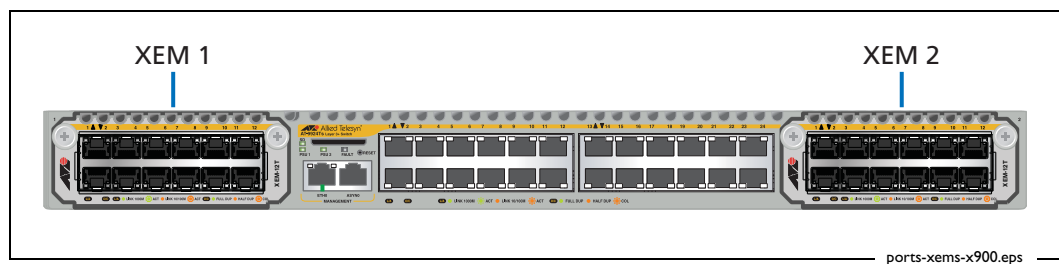

For switches with multiple rows of XEMs, the numbering starts at the top left-hand corner, as the following figure shows for a SwitchBlade x908:

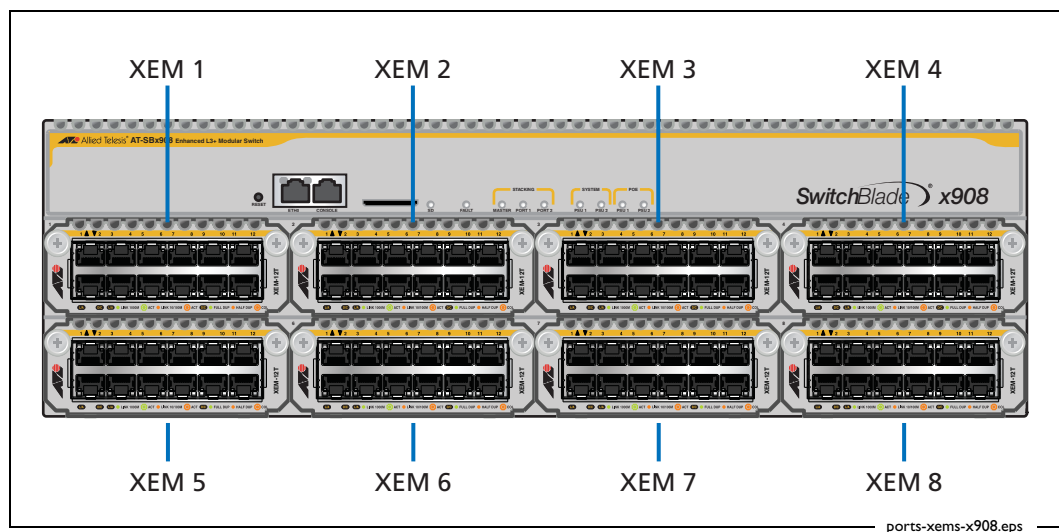

The XEM bay number is printed on the top left-hand corner of each XEM bay.

- the third number (z) is the port number.

Port ranges

Continuous To configure a continuous range of ports at the same time, enter the range in either of the formats:

```
portx.y.z-portx.y.z
```

```
portx.y.z-x.y.z
```

For example, to configure the same interface setting on base switch ports 10-20, enter the Global Configuration mode command:

```
awplus(config)#interface port1.0.10-1.0.20
```

Non-continuous To configure a non-continuous set of ports at the same time, enter the ports as a comma-separated list, like this:

```
portx.y.z,portx.y.z
```

For example, to configure the same interface setting on base switch ports 1 and 5, enter the Global Configuration mode command:

```
awplus(config)#interface port1.0.1,port1.0.5
```

You can combine a hyphen-separated range and a comma-separated list. For example, to configure the same interface setting on base switch ports 1-3 and 5, enter the Global Configuration mode command:

```
awplus(config)#interface port1.0.1-1.0.3,port1.0.5
```

Port speed, duplex mode, and polarity

In most networks, you will not need to change the port speed, duplex mode, or polarity, because the ports automatically negotiate suitable settings.

This section describes how to change them, if you need to.

Enter Interface mode

All three are interface settings, so you first enter Interface Configuration mode for the port or port range you want to configure, by entering one of the commands:

```
awplus(config)#interface portx.y.z
awplus(config)#interface portx.y.z-x.y.z
```

The prompt changes to:

```
awplus(config-if)#
```

How to set the speed

The following table shows the speed options for each type of port.

Port type	Speed Options
non-SFP RJ-45 copper ports	auto (the default) 10 100 1000
supported tri-speed copper SFPs	auto (the default) 10 100 1000
100Mb fibre SFPs	100 (the default)
1000Mb fibre SFPs	auto (the default) 1000
XFP modules	auto (the default) 10000

To change the speed, first enter Interface Configuration mode for the port or port range you want to configure. Then enter the command:

```
awplus(config-if)#speed <value>
```

For example, to set the speed of a tri-speed port to 100Mbps, enter the command:

```
awplus(config-if)#speed 100
```

To return the port to autonegotiating its speed, enter the command:

```
awplus(config-if)#speed auto
```

How to set the duplex mode

By default, ports autonegotiate duplex mode (except for 100Base-FX ports which do not support autonegotiation, so default to full duplex mode).

To change this, first enter Interface Configuration mode for the port or port range you want to configure.

Then, to specify full duplex, enter the command:

```
awplus(config-if)#duplex full
```

To specify half duplex, enter the command:

```
awplus(config-if)#duplex half
```

To autonegotiate duplex mode, enter the command:

```
awplus(config-if)#duplex auto
```

How to set the polarity

By default, ports use auto MDI/MDI-X.

To change this, first enter Interface Configuration mode for the port or port range you want to configure.

Then, to specify MDI, enter the command:

```
awplus(config-if)#polarity mdi
```

To specify MDI-X (crossover), enter the command:

```
awplus(config-if)#polarity mdix
```

To return to auto-detection, enter the command:

```
awplus(config-if)#polarity auto
```

Basic VLAN and IP configuration

This section configures a switch in a simple four-VLAN network, shown in the following figure.

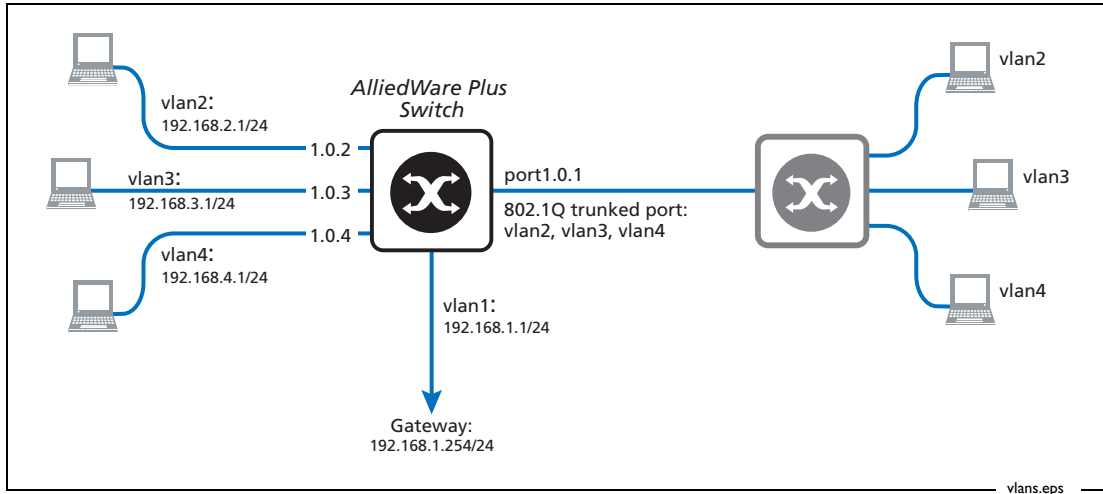

In this network, VLANs 2-4 span two switches. The section configures the left-hand switch in the above figure. This switch is connected to a second switch via port 1.0.1.

For the complete script for this example, see ["Script for VLAN example" on page 26](#).

I. Create VLANs 2-4

Enter Global Configuration mode and enter the command:

```
awplus(config)#vlan database
```

This puts you into VLAN mode. To create the VLANs, enter the commands:

```
awplus(config-vlan)#vlan 2 name vlan2
awplus(config-vlan)#vlan 3 name vlan3
awplus(config-vlan)#vlan 4 name vlan4
```

The AlliedWare Plus OS automatically enables new VLANs, and therefore adds the following line to the running-config:

```
vlan 2-4 state enable
```

2. Associate the VLANs with port1.0.1

VLANs are configured as an attribute of switch ports. This means that you go into Interface Configuration mode to configure the switch ports, and specify the VLANs you want to associate with each switch port.

From Global Configuration mode, enter Interface Configuration mode by entering the command:

```
awplus(config)#interface port1.0.1
```

Traffic for all three VLANs goes over port1.0.1, so next make this port an 802.1Q trunk, by entering the command:

```
awplus(config-if)#switchport mode trunk
```

Finally, associate the port with the appropriate VLANs:

```
awplus(config-if)#switchport trunk allowed
                        vlan add 2-4
```

Note that by default the port's native VLAN is VLAN 1. The native VLAN is the VLAN that the port uses for untagged packets.

Tip:

In the AlliedWare OS, we add ports to VLANs as tagged ports. In the AlliedWare Plus OS, we associate VLANs with a trunk mode port. The port behaviour is the same.

3. Associate VLANs with ports 1.0.2-1.0.3

Change to configuring port1.0.2 by entering the command:

```
awplus(config-if)#interface port1.0.2
```

Associate vlan2 with the port, by entering the command:

```
awplus(config-if)#switchport access vlan 2
```

Ports in access mode send and receive untagged packets.

Similarly, associate vlan3 with port1.0.3, and vlan4 with port1.0.4, by entering the commands:

```
awplus(config-if)#interface port1.0.3
```

```
awplus(config-if)#switchport access vlan 3
```

```
awplus(config-if)#interface port1.0.4
```

```
awplus(config-if)#switchport access vlan 4
```

Tip:

You do not have to leave Interface Configuration mode to change interfaces.

4. Assign IP addresses to the VLANs

Change to configuring vlan1 by entering the command:

```
awplus(config-if)#interface vlan1
```

Assign the IP address and subnet by entering the command:

```
awplus(config-if)#ip address 192.168.1.1/24
```

Similarly, configure the other VLANs by entering the commands:

```
awplus(config-if)#interface vlan2
```

```
awplus(config-if)#ip address 192.168.2.1/24
```

```
awplus(config-if)#interface vlan3
```

```
awplus(config-if)#ip address 192.168.3.1/24
```

```
awplus(config-if)#interface vlan4
```

```
awplus(config-if)#ip address 192.168.4.1/24
```

5. Create a route to the default gateway

Return to Global Configuration mode by entering the command:

```
awplus(config-if)#exit
```

Then enter the command:

```
awplus(config)#ip route 0.0.0.0/0 192.168.1.254
```

6. Check the configuration

To check the configuration, first return to Privileged Exec mode by entering the command:

```
awplus(config)#exit
```

To see port membership and state for the VLANs, enter the command:

```
awplus#show vlan brief
```

The output looks like this:

VLAN ID	Name	Type	State	Member ports (u)-Untagged, (t)-Tagged
1	default	STATIC	ACTIVE	port1.0.1(u) port1.0.5(u) port1.0.6(u) port1.0.7(u) port1.0.8(u) port1.0.9(u) port1.0.10(u) port1.0.11(u) port1.0.12(u) port1.0.13(u) port1.0.14(u) port1.0.15(u) port1.0.16(u) port1.0.17(u) port1.0.18(u) port1.0.19(u) port1.0.20(u) port1.0.21(u) port1.0.22(u) port1.0.23(u) port1.0.24(u)
2	vlan2	STATIC	ACTIVE	port1.0.1(t) port1.0.2(u)
3	vlan3	STATIC	ACTIVE	port1.0.1(t) port1.0.3(u)
4	vlan4	STATIC	ACTIVE	port1.0.1(t) port1.0.4(u)

To see the VLANs associated with each switch port, enter the command:

```
awplus#show interface switchport
```

The output looks like this:

```

Interface name      : port1.0.1
Switchport mode    : trunk
Ingress filter     : enable
Acceptable frame types : all
Default Vlan      : 1
Configured Vlans   :      1      2      3      4
Interface name     : port1.0.2
Switchport mode    : access
Ingress filter     : enable
Acceptable frame types : all
Default Vlan      : 2
Configured Vlans   :      2
.
.
.

```

To see VLAN interface details, enter the command:

```
awplus# show interface | begin vlan
```

The output looks like this:

```
Interface vlan1
Scope: both
Link is UP, administrative state is UP
Hardware is VLAN, address is 0000.cd24.0331 (bia 0000.cd24.0331)
IPv4 address 192.168.1.1/24 broadcast 192.168.1.255
VRRP Master of : VRRP is not configured on this interface.
index 6 metric 1 mtu 1500
arp ageing timeout 300
<UP,BROADCAST,RUNNING,MULTICAST>
VRF Binding: Not bound
  input packets 0, bytes 0, dropped 0, multicast packets 0
  output packets 2, bytes 200, multicast packets 0 broadcast packets 0
Interface vlan2
Scope: both
Link is DOWN, administrative state is UP
Hardware is VLAN, address is 0000.cd24.0331 (bia 0000.cd24.0331)
IPv4 address 192.168.2.1/24 broadcast 192.168.2.255
VRRP Master of : VRRP is not configured on this interface.
index 7 metric 1 mtu 1500
arp ageing timeout 300
<UP,BROADCAST,MULTICAST>
VRF Binding: Not bound
  input packets 0, bytes 0, dropped 0, multicast packets 0
  output packets 0, bytes 0, multicast packets 0 broadcast packets 0
.
.
.
```

Rapid Spanning Tree Protocol (RSTP)

This example takes the network from "Basic VLAN and IP configuration" on page 7 and adds two more switches in a ring topology, as the following figure shows. The switches use RSTP to prevent layer 2 loops in the network.

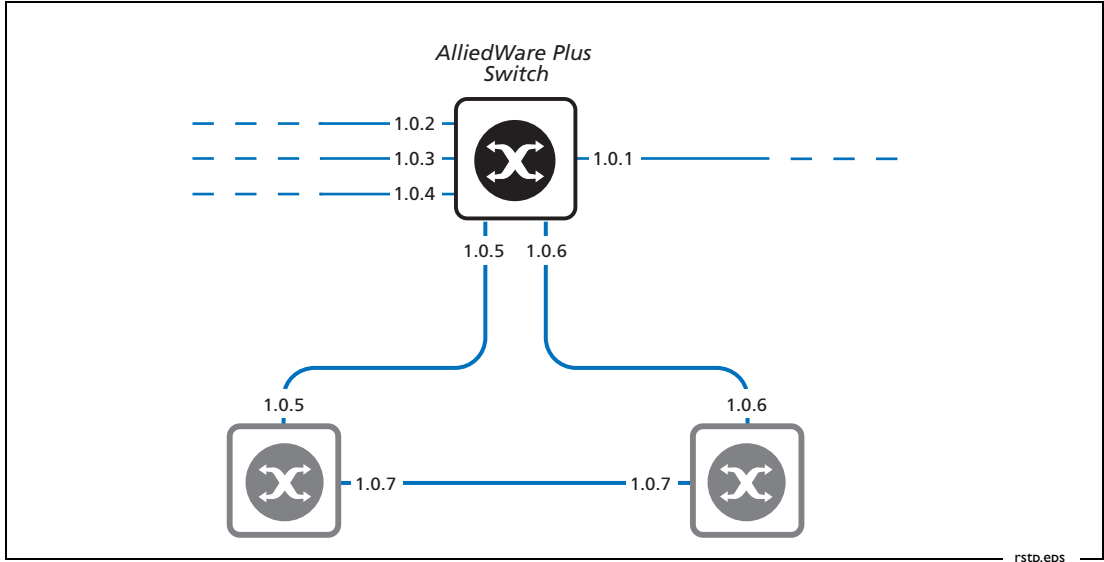

The default configuration

RSTP is enabled with default settings on all switch ports. Therefore, no further configuration is required for the above network.

The following figure shows the MAC addresses of each switch and the stable port states. By default, all switches have the same root bridge priority, so the switch with the lowest MAC address becomes the root bridge.

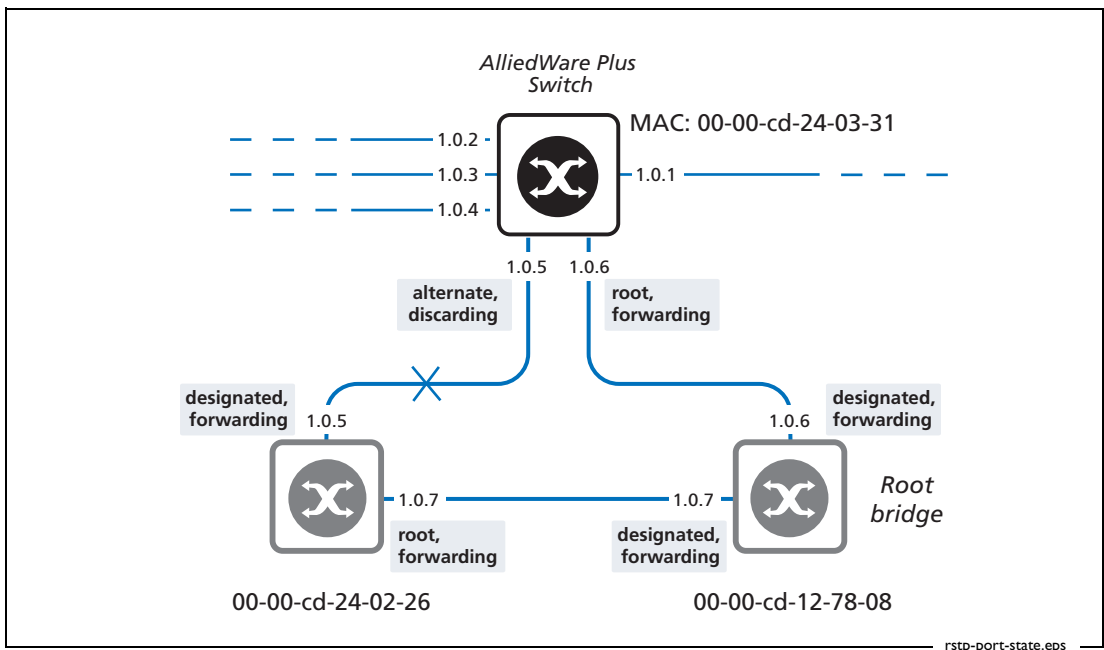

To see the STP state, enter Privileged Exec mode and enter the command:

```
awplus#show spanning-tree
```

The output looks like this:

```
% 1: Bridge up - Spanning Tree Enabled
% 1: Root Path Cost 200000 - Root Port 5006 - Bridge Priority 32768
% 1: Forward Delay 15 - Hello Time 2 - Max Age 20
% 1: Root Id 80000000cd127808
% 1: Bridge Id 80000000cd240331
% 1: last topology change Thu May 31 00:27:28 2007
% 1: portfast bpdu-filter disabled
% 1: portfast bpdu-guard disabled
% 1: portfast errdisable timeout disabled
% 1: portfast errdisable timeout interval 300 sec
%
.
.
.
%
% port1.0.5: Port 5005 - Id 838d - Role Alternate - State Discarding
% port1.0.5: Designated Path Cost 200000
% port1.0.5: Configured Path Cost 200000 - Add type Explicit ref count 1
% port1.0.5: Designated Port Id 838d - Priority 128 -
% port1.0.5: Root 80000000cd127808
% port1.0.5: Designated Bridge 80000000cd240226
% port1.0.5: Message Age 1 - Max Age 20
% port1.0.5: Hello Time 2 - Forward Delay 15
% port1.0.5: Forward Timer 0 - Msg Age Timer 0 - Hello Timer 1 - topo change timer 0
% port1.0.5: forward-transitions 2
% port1.0.5: Version Rapid Spanning Tree Protocol - Received RSTP - Send RSTP
% port1.0.5: No portfast configured - Current portfast off
% port1.0.5: portfast bpdu-guard default - Current portfast bpdu-guard off
% port1.0.5: portfast bpdu-filter default - Current portfast bpdu-filter off
% port1.0.5: no root guard configured - Current root guard off
% port1.0.5: Configured Link Type point-to-point - Current point-to-point
%
% port1.0.6: Port 5006 - Id 838e - Role Rootport - State Forwarding
% port1.0.6: Designated Path Cost 0
% port1.0.6: Configured Path Cost 200000 - Add type Explicit ref count 1
% port1.0.6: Designated Port Id 8006 - Priority 128 -
% port1.0.6: Root 80000000cd127808
% port1.0.6: Designated Bridge 80000000cd127808
% port1.0.6: Message Age 1 - Max Age 20
% port1.0.6: Hello Time 2 - Forward Delay 15
% port1.0.6: Forward Timer 0 - Msg Age Timer 5 - Hello Timer 1 - topo change timer 0
% port1.0.6: forward-transitions 3
% port1.0.6: Version Rapid Spanning Tree Protocol - Received RSTP - Send RSTP
% port1.0.6: No portfast configured - Current portfast off
% port1.0.6: portfast bpdu-guard default - Current portfast bpdu-guard off
% port1.0.6: portfast bpdu-filter default - Current portfast bpdu-filter off
% port1.0.6: no root guard configured - Current root guard off
% port1.0.6: Configured Link Type point-to-point - Current point-to-point
```

Note that the Bridge ID is 80000000cd240331, and that other IDs follow the same pattern. This is made up of:

- 8000—the switch's root bridge priority in hexadecimal
- 0000cd240331—the switch's MAC address.

How to change the root bridge priority

The default root bridge priority is 32768 (8000 in hexadecimal). When all switches have the same priority, the switch with the lowest MAC address becomes the root bridge.

If you want the AlliedWare Plus switch to be the root bridge, you can do this by setting the priority to a value lower than 32768. For example, to set the priority value to 8192, enter Global Configuration mode and enter the command:

```
awplus(config)#spanning-tree priority 8192
```

Enter priority as a decimal value. It is in increments of 4096. If you enter a number that is not a multiple of 4096, the switch rounds the number down.

The following figure shows the new port states after the priority change.

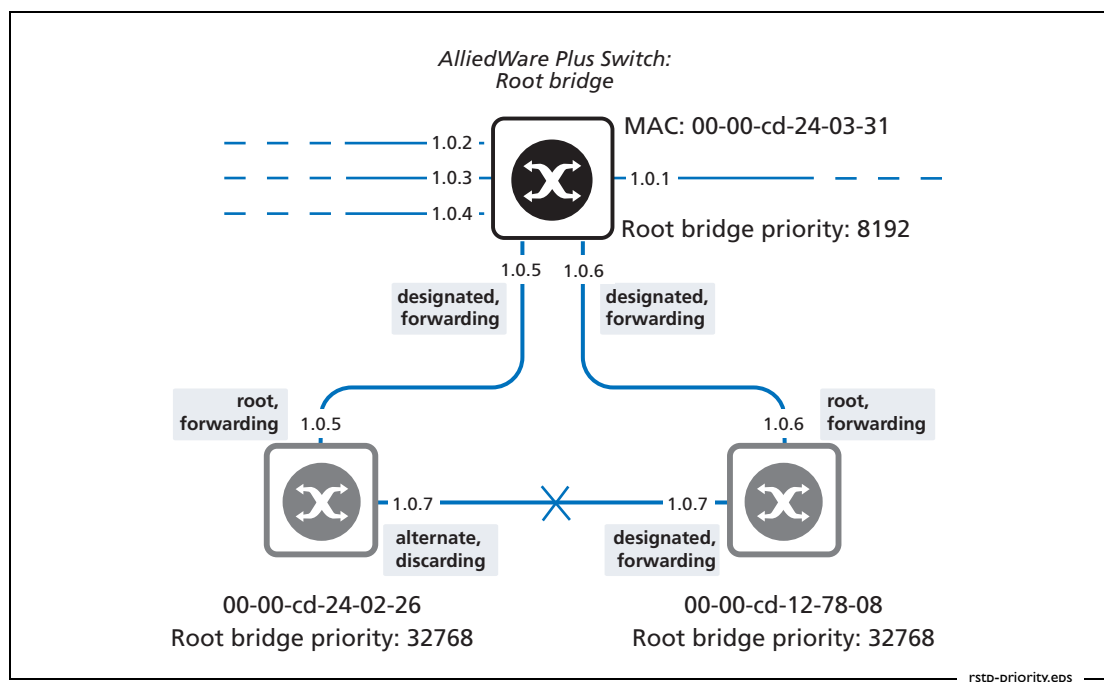

How to set ports as edge ports

In this example's network, ports 1.0.2, 1.0.3, and 1.0.4 are attached to devices that cannot generate BPDUs (such as workstations) and therefore should be RSTP edge ports.

To set them as edge ports, enter Global Configuration mode and enter the commands:

```
awplus(config)#interface port1.0.2-1.0.4
awplus(config-if)#spanning-tree edgeport
```

Multiple Spanning Tree Protocol (MSTP)

This example takes the looped network from "[Rapid Spanning Tree Protocol \(RSTP\)](#)" on [page 12](#) and configures MSTP instead of RSTP. MSTP lets you block different VLANs at different points in the network. This gives you greater control over the flow of traffic in your network, and allows more efficient use of bandwidth by using more switch ports.

As the following figure shows, this example discards traffic for:

- vlans 2 and 3 between the AlliedWare Plus switch and Switch 2
- vlan 4 between Switches 2 and 3

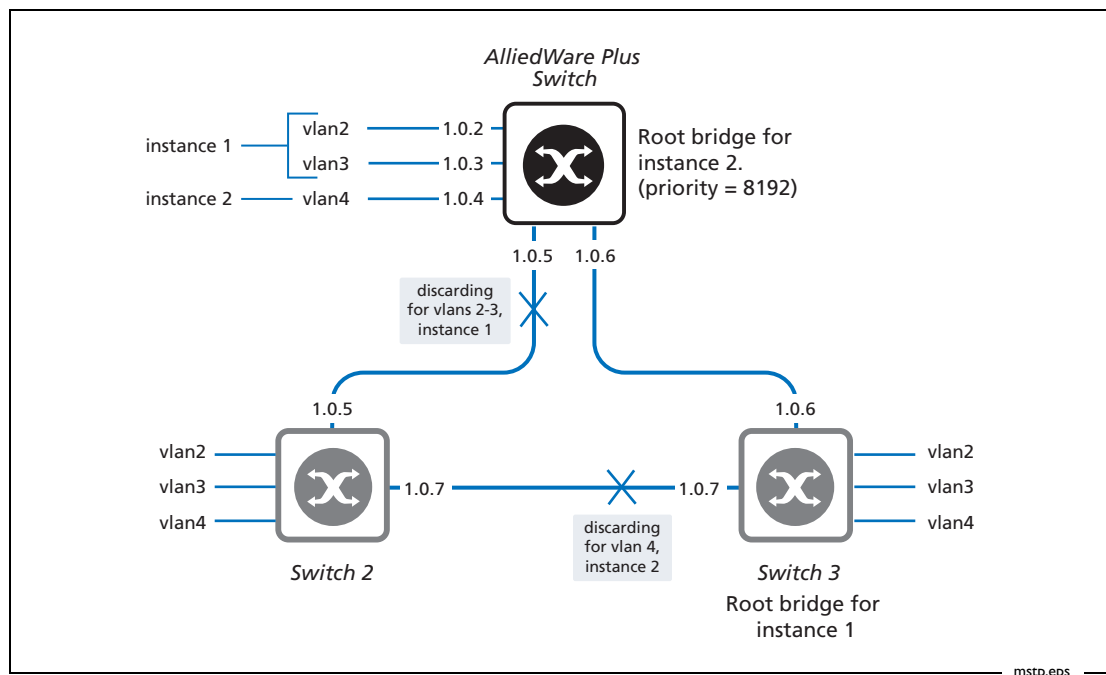

For the complete script for this example, see "[Script for MSTP example](#)" on [page 28](#).

I. Create the VLANs

Enter Global Configuration mode and enter the command:

```
awplus(config)#vlan database
```

This puts you into VLAN mode. To create the VLANs, enter the commands:

```
awplus(config-vlan)#vlan 2 name vlan2
```

```
awplus(config-vlan)#vlan 3 name vlan3
```

```
awplus(config-vlan)#vlan 4 name vlan4
```

2. Associate VLANs with ports

Ports 1.0.2-1.0.4 are in access mode. Enter the commands:

```
awplus(config-vlan)#interface port1.0.2
awplus(config-if)#switchport access vlan 2
awplus(config-if)#interface port1.0.3
awplus(config-if)#switchport access vlan 3
awplus(config-if)#interface port1.0.4
awplus(config-if)#switchport access vlan 4
```

Ports 1.0.5-1.0.6 are in trunk mode. Enter the commands:

```
awplus(config-if)#interface port1.0.5-1.0.6
awplus(config-if)#switchport mode trunk
awplus(config-if)#switchport trunk allowed vlan add 2-4
```

Note that by default the port's native VLAN—the VLAN that the port uses for untagged packets—is VLAN 1. Some control packets are untagged, including MSTP CIST BPDUs.

Leave Interface Configuration mode by entering the command:

```
awplus(config-if)#exit
```

3. Select MSTP as the spanning tree mode

Enter Global Configuration mode and enter the command:

```
awplus(config)#spanning-tree mode mstp
```

4. Configure MST instances, region, and revision number

Enter MST mode by entering the command:

```
awplus(config)#spanning-tree mst configuration
```

To allow MSTP to block different VLANs at different places in the loop, create two instances. Enter the commands:

```
awplus(config-mst)#instance 1 vlan 2-3
awplus(config-mst)#instance 2 vlan 4
```

Specify the MSTP region and revision number. Enter the commands:

```
awplus(config-mst)#region awplus
awplus(config-mst)#revision 1
```

Note that all MSTP devices in this network must have the same region and revision number.

5. Associate the instances with the appropriate switch ports

Enter Interface Configuration mode for the trunk ports 1.0.5-1.0.6 by entering the command:

```
awplus(config-mst)#interface port1.0.5-1.0.6
```

Attach the instances to these ports by entering the commands:

```
awplus(config-if)#spanning-tree mst instance 1
awplus(config-if)#spanning-tree mst instance 2
```

Attach the appropriate instance to each access port by entering the commands:

```
awplus(config-if)#interface port1.0.2-1.0.3
awplus(config-if)#spanning-tree mst instance 1
awplus(config-if)#interface port1.0.4
awplus(config-if)#spanning-tree mst instance 2
```

6. Force the AlliedWare Plus switch to be the root bridge for instance 2

MSTP lets you distribute traffic more efficiently across the network by blocking different links for different VLANs. You do this by making separate switches into the root bridge for each MSTP instance, so that each MSTP instance blocks a different link.

The configuration described in the previous steps blocks port1.0.5 on the AlliedWare Plus switch for traffic for all the VLANs. This is because both instances have the same root bridge.

To block traffic between Switches 2 and 3, we change the priority of the AlliedWare Plus switch, so that it becomes the root bridge. We only want this to happen for traffic in vlan4, so we only change the priority for instance 2.

To do this, first enter MSTP mode by entering the command:

```
awplus(config-if)#spanning-tree mst configuration
```

Then set the priority by entering the command:

```
awplus(config-mst)#instance 2 priority 8192
```

In this example's network, you can get the desired behaviour by setting the priority to any number lower than the default of 32768.

7. Check the configuration

To check for general information about MSTP, and the CIST settings, enter Privileged Exec mode and enter the command:

```
awplus#show spanning-tree
```

The output shows that Switch 3 is the CIST root bridge:

```
% 1: Bridge up - Spanning Tree Enabled
% 1: CIST Root Path Cost 0 - CIST Root Port 5006 - CIST Bridge Priority 32768
% 1: Forward Delay 15 - Hello Time 2 - Max Age 20 - Max-hops 20
% 1: CIST Root Id 80000000cd127808
% 1: CIST Reg Root Id 80000000cd127808
% 1: CIST Bridge Id 80000000cd240331
% 1: portfast bpdu-filter disabled
% 1: portfast bpdu-guard disabled
% 1: portfast errdisable timeout disabled
% 1: portfast errdisable timeout interval 300 sec
.
.
.
% port1.0.5: Port 5005 - Id 838d - Role Alternate - State Discarding
% port1.0.5: Designated External Path Cost 0 -Internal Path Cost 200000
% port1.0.5: Configured Path Cost 20000 - Add type Explicit ref count 3
% port1.0.5: Designated Port Id 8005 - CIST Priority 128 -
% port1.0.5: CIST Root 80000000cd127808
% port1.0.5: Regional Root 80000000cd127808
% port1.0.5: Designated Bridge 80000000cd240226
% port1.0.5: Message Age 0 - Max Age 20
% port1.0.5: CIST Hello Time 2 - Forward Delay 15
% port1.0.5: CIST Forward Timer 0 - Msg Age Timer 4 - Hello Timer 0 - topo change
timer 0
% port1.0.5: forward-transitions 1
% port1.0.5: Version Multiple Spanning Tree Protocol - Received MSTP - Send MSTP
% port1.0.5: No portfast configured - Current portfast off
% port1.0.5: portfast bpdu-guard default - Current portfast bpdu-guard off
% port1.0.5: portfast bpdu-filter default - Current portfast bpdu-filter off
% port1.0.5: no root guard configured - Current root guard off
% port1.0.5: Configured Link Type point-to-point - Current point-to-point
.
.
.
```

To check for the state of each port for each instance, enter Privileged Exec mode and enter the command:

```
awplus#show spanning-tree mst instance <value> interface port<value>
```

For **instance 1 and port1.0.5**—vlan2 and vlan3—the output shows that Switch 3 is the MSTI root bridge and that the port is discarding packets:

```
awplus#show spanning-tree mst instance 1 interface port1.0.5
% 1: MSTI Root Path Cost 200000 - MSTI Root Port 5006 - MSTI Bridge Priority 32768
% 1: MSTI Root Id 80010000cd127808
% 1: MSTI Bridge Id 80010000cd240331
% port1.0.5: Port 5005 - Id 838d - Role Alternate - State Discarding
% port1.0.5: Designated Internal Path Cost 200000 - Designated Port Id 8005
% port1.0.5: Configured Internal Path Cost 20000
% port1.0.5: Configured CST External Path cost 20000
% port1.0.5: CST Priority 128 - MSTI Priority 128
% port1.0.5: Designated Root 80010000cd127808
% port1.0.5: Designated Bridge 80010000cd240226
% port1.0.5: Message Age 0 - Max Age 0
% port1.0.5: Hello Time 2 - Forward Delay 15
% port1.0.5: Forward Timer 0 - Msg Age Timer 4 - Hello Timer 1
```

For **instance 2 and port1.0.5**—vlan4—the output shows that the AlliedWare Plus switch is the MSTI root bridge and that the port is forwarding packets:

```
awplus#show spanning-tree mst instance 2 interface port1.0.5
% 1: MSTI Root Path Cost 0 - MSTI Root Port 0 - MSTI Bridge Priority 8192
% 1: MSTI Root Id 20020000cd240331
% 1: MSTI Bridge Id 20020000cd240331
% port1.0.5: Port 5005 - Id 838d - Role Designated - State Forwarding
% port1.0.5: Designated Internal Path Cost 0 - Designated Port Id 838d
% port1.0.5: Configured Internal Path Cost 20000
% port1.0.5: Configured CST External Path cost 20000
% port1.0.5: CST Priority 128 - MSTI Priority 128
% port1.0.5: Designated Root 20020000cd240331
% port1.0.5: Designated Bridge 20020000cd240331
% port1.0.5: Message Age 0 - Max Age 0
% port1.0.5: Hello Time 2 - Forward Delay 15
% port1.0.5: Forward Timer 0 - Msg Age Timer 0 - Hello Timer 1
```

For **instance 1 and port1.0.6**—vlan2 and vlan3—the output shows that the port is forwarding packets. The port role is *rootport*, indicating that it is the shortest path to the root bridge for the AlliedWare Plus switch.

```
awplus#show spanning-tree mst instance 1 interface port1.0.6
% 1: MSTI Root Path Cost 200000 - MSTI Root Port 5006 - MSTI Bridge Priority 32768
% 1: MSTI Root Id 80010000cd127808
% 1: MSTI Bridge Id 80010000cd240331
%   port1.0.6: Port 5006 - Id 838e - Role Rootport - State Forwarding
%   port1.0.6: Designated Internal Path Cost 0 - Designated Port Id 8006
%   port1.0.6: Configured Internal Path Cost 200000
%   port1.0.6: Configured CST External Path cost 200000
%   port1.0.6: CST Priority 128 - MSTI Priority 128
%   port1.0.6: Designated Root 80010000cd127808
%   port1.0.6: Designated Bridge 80010000cd127808
%   port1.0.6: Message Age 0 - Max Age 0
%   port1.0.6: Hello Time 2 - Forward Delay 15
%   port1.0.6: Forward Timer 0 - Msg Age Timer 5 - Hello Timer 1
```

For **instance 2 and port1.0.6**—vlan4—the output shows that the port is forwarding packets:

```
awplus#show spanning-tree mst instance 2 interface port1.0.6
% 1: MSTI Root Path Cost 0 - MSTI Root Port 0 - MSTI Bridge Priority 8192
% 1: MSTI Root Id 20020000cd240331
% 1: MSTI Bridge Id 20020000cd240331
%   port1.0.6: Port 5006 - Id 838e - Role Designated - State Forwarding
%   port1.0.6: Designated Internal Path Cost 0 - Designated Port Id 838e
%   port1.0.6: Configured Internal Path Cost 200000
%   port1.0.6: Configured CST External Path cost 200000
%   port1.0.6: CST Priority 128 - MSTI Priority 128
%   port1.0.6: Designated Root 20020000cd240331
%   port1.0.6: Designated Bridge 20020000cd240331
%   port1.0.6: Message Age 0 - Max Age 0
%   port1.0.6: Hello Time 2 - Forward Delay 15
%   port1.0.6: Forward Timer 0 - Msg Age Timer 0 - Hello Timer 0
```

Link Aggregation

This section has examples of two ways to aggregate ports together:

- dynamically using LACP
- statically, on [page 24](#)

Both examples configure the AlliedWare Plus switch that is shown in the following figure.

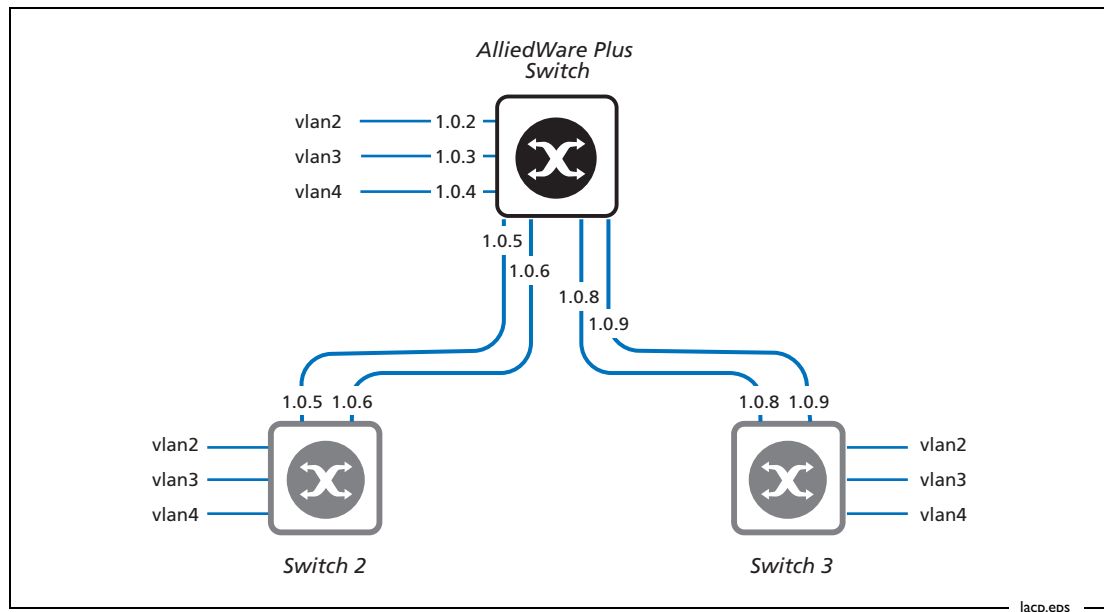

How to configure Link Aggregation Control Protocol (LACP)

I. Create the VLANs

Enter Global Configuration mode and enter the command:

```
awplus(config)#vlan database
```

This puts you into VLAN mode. To create the VLANs, enter the commands:

```
awplus(config-vlan)#vlan 2 name vlan2
```

```
awplus(config-vlan)#vlan 3 name vlan3
```

```
awplus(config-vlan)#vlan 4 name vlan4
```

2. Associate VLANs with ports

Ports 1.0.2-1.0.4 are in access mode. Enter the commands:

```
awplus(config-vlan)#interface port1.0.2
awplus(config-if)#switchport access vlan 2
awplus(config-if)#interface port1.0.3
awplus(config-if)#switchport access vlan 3
awplus(config-if)#interface port1.0.4
awplus(config-if)#switchport access vlan 4
```

Ports 1.0.5-1.0.6 and 1.0.8-1.0.9 are in trunk mode. Enter the commands:

```
awplus(config-if)#interface port1.0.5-1.0.6,port1.0.8-1.0.9
awplus(config-if)#switchport mode trunk
awplus(config-if)#switchport trunk allowed vlan add 2-4
```

3. Create the channel groups

Create a channel group for each set of ports that you want to aggregate, by entering the commands:

```
awplus(config)#interface port1.0.5-1.0.6
awplus(config-if)#channel-group 1 mode active
awplus(config)#interface port1.0.8-1.0.9
awplus(config-if)#channel-group 2 mode active
```

4. Check the configuration

Enter Privileged Exec mode and enter the command:

```
awplus#show etherchannel
```

The output looks like this:

```
% LACP Aggregator: po1
% Member:
   port1.0.5
   port1.0.6
% LACP Aggregator: po2
% Member:
   port1.0.8
   port1.0.9
```

For detailed information about a port (1.0.5 in this case), enter the command:

```
awplus#show port etherchannel port1.0.5
```

The output looks like this:

```
% LACP link info: port1.0.5 - 5005
% LAG ID: 0x8000,00-00-cd-24-03-31
% Partner oper LAG ID: 0x8000,00-00-cd-24-02-26
% Actor priority: 0x8000 (32768)
% Admin key: 0x0001 (1) Oper key: 0x0001 (1)
% Physical admin key:(7)
% Receive machine state : Current
% Periodic Transmission machine state : Fast periodic
% Mux machine state : Collecting/Distributing
% Oper state: ACT:1 TIM:0 AGG:1 SYN:1 COL:1 DIS:1 DEF:0 EXP:0
% Partner oper state: ACT:1 TIM:1 AGG:0 SYN:1 COL:1 DIS:1 DEF:0 EXP:0
% Partner link info: admin port 0
% Partner oper port: 5
% Partner admin LAG ID: 0x0000-00:00:00:00:0000
% Admin state: ACT:1 TIM:0 AGG:1 SYN:0 COL:0 DIS:0 DEF:1 EXP:0
% Partner admin state: ACT:0 TIM:0 AGG:1 SYN:0 COL:0 DIS:0 DEF:1 EXP:0
% Partner system priority - admin:0x8000 - oper:0x8000
% Aggregator ID: 4501
```

Stopping LACP

If you want to stop LACP, enter Interface Configuration mode for the ports in the channel group, and enter the command:

```
awplus(config-if)#no channel-group
```

How to configure static aggregation

This section describes how to use statically-aggregated ports instead of LACP. For the network diagram, see [page 21](#).

First create the VLANs and associate them with ports, by following [step 1 on page 21](#) and [step 2 on page 22](#).

Then instead of creating channel groups ([step 3 on page 22](#)), do the following steps:

3. Create the static channel groups

Create a static channel group for each set of ports that you want to aggregate, by entering the commands:

```
awplus(config)#interface port1.0.5-1.0.6
awplus(config-if)#static-channel-group 1
awplus(config)#interface port1.0.8-1.0.9
awplus(config-if)#static-channel-group 2
```

4. Check the configuration

Enter Privileged Exec mode and enter the command:

```
awplus#show static-channel-group
```

The output looks like this:

```
% Static Aggregator: sa1
% Member:
  port1.0.5
  port1.0.6
% Static Aggregator: sa2
% Member:
  port1.0.8
  port1.0.9
```

Port mirroring

This example shows how to send port 1.0.23 a copy of all traffic that ingresses and egresses port 1.0.2.

In other words, port 1.0.23 is the mirror port, and port 1.0.2 is the port that is being mirrored.

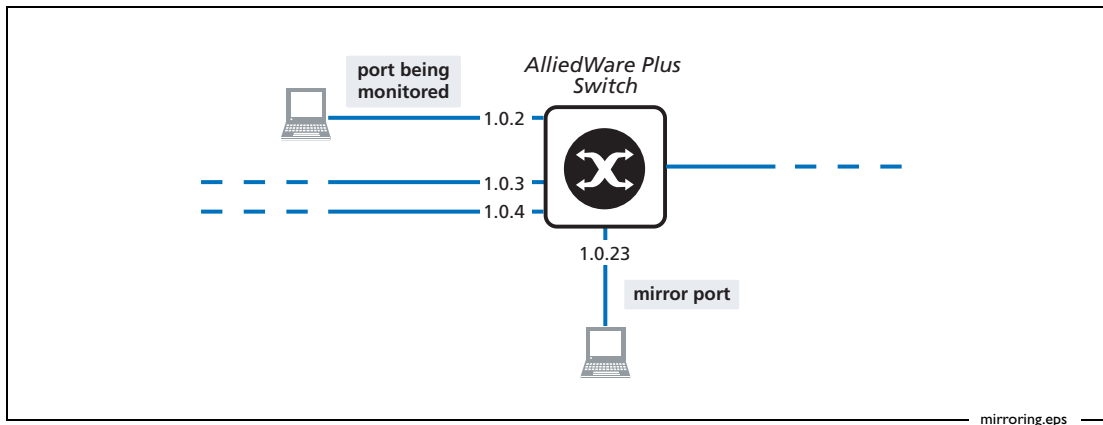

First, enter Global Configuration mode and enter the command:

```
awplus(config)#interface port1.0.23
```

This puts you in Interface Configuration mode for port1.0.23. Then enter the command:

```
awplus(config-if)#mirror interface port1.0.2 direction both
```

To check the configuration, enter Privileged Exec mode and enter the command:

```
awplus#show mirror
```

The output looks like this:

```
Mirror Test Port Name: port1.0.23
Mirror option: Enabled
Mirror direction: both
Monitored Port Name: port1.0.2
```

Appendix: Complete configuration scripts

This section contains the configuration scripts for two of the examples in this How To Note. The scripts were produced by entering the following command:

```
awplus#show running-config
```

Script for VLAN example

```
service password-encryption
!
log record-priority
username manager privilege 15 password 8 $1$bJoVec4D$JwOJGPr7YqoExA0GVasdE0
!
platform jumboframe
platform routingratio ipv4only
!
service telnet
!
ip domain-lookup
!
no ip multicast-routing
!
maximum-paths 8
spanning-tree mode rstp
!
vlan database
vlan 2 name vlan2
vlan 3 name vlan3
vlan 4 name vlan4
vlan 2-4 state enable
!
interface eth0
!
interface port1.0.1
switchport
switchport mode trunk
switchport trunk allowed vlan add 2
switchport trunk allowed vlan add 3
switchport trunk allowed vlan add 4
!
interface port1.0.2
switchport
switchport mode access
switchport access vlan 2
!
interface port1.0.3
switchport
switchport mode access
switchport access vlan 3
!
```

```
interface port1.0.4
  switchport
  switchport mode access
  switchport access vlan 4
!
interface port1.0.5-1.0.24
  switchport
  switchport mode access
!
interface vlan1
  ip address 192.168.1.1/24
!
interface vlan2
  ip address 192.168.2.1/24
!
interface vlan3
  ip address 192.168.3.1/24
!
interface vlan4
  ip address 192.168.4.1/24
!
ip route 0.0.0.0/0 192.168.1.254
!
line con 0
  login
line vty 0 32
  login
!
end
```

Script for MSTP example

```
!  
service password-encryption  
!  
log record-priority  
username manager privilege 15 password 8 $1$bJoVec4D$JwOJGPr7YqoExA0GVasde0  
!  
platform jumboframe  
platform routingratio ipv4only  
!  
service telnet  
!  
ip domain-lookup  
!  
no ip multicast-routing  
!  
spanning-tree mst config  
  instance 1 vlan 2  
  instance 1 vlan 3  
  instance 2 vlan 4  
  instance 2 priority 8192  
  region awplus  
  revision 1  
!  
maximum-paths 8  
spanning-tree mode mstp  
!  
vlan database  
  vlan 2 name vlan2  
  vlan 3 name vlan3  
  vlan 4 name vlan4  
  vlan 2-4 state enable  
!  
interface eth0  
!  
interface port1.0.1  
  switchport  
  switchport mode trunk  
  switchport trunk allowed vlan add 2-4  
!  
interface port1.0.2  
  switchport  
  switchport mode access  
  switchport access vlan 2  
  spanning-tree mst instance 1  
!  
interface port1.0.3  
  switchport  
  switchport mode access  
  switchport access vlan 3  
  spanning-tree mst instance 1  
!
```

```
interface port1.0.4
  switchport
  switchport mode access
  switchport access vlan 4
  spanning-tree mst instance 2
!
interface port1.0.5-1.0.6
  switchport
  switchport mode trunk
  switchport trunk allowed vlan add 2-4
  spanning-tree mst instance 1
  spanning-tree mst instance 2
!
interface port1.0.7-1.0.24
  switchport
  switchport mode access
!interface vlan1
  ip address 192.168.1.1/24
!
interface vlan2
  ip address 192.168.2.1/24
!
interface vlan3
  ip address 192.168.3.1/24
!
interface vlan4
  ip address 192.168.4.1/24
!
ip route 0.0.0.0/0 192.168.1.254
!
line con 0
  login
line vty 0 32
  login
!
end
```

USA Headquarters | 19800 North Creek Parkway | Suite 200 | Bothell | WA 98011 | USA | T: +1 800 424 4284 | F: +1 425 481 3895
European Headquarters | Via Motta 24 | 6830 Chiasso | Switzerland | T: +41 91 69769.00 | F: +41 91 69769.11
Asia-Pacific Headquarters | 11 Tai Seng Link | Singapore | 534182 | T: +65 6383 3832 | F: +65 6383 3830
www.alliedtelesis.com

© 2007 Allied Telesis, Inc. All rights reserved. Information in this document is subject to change without notice. Allied Telesis is a trademark or registered trademark of Allied Telesis, Inc. in the United States and other countries. All company names, logos, and product designs that are trademarks or registered trademarks are the property of their respective owners.

C613-16106-00 REV B